

Timbre Panels

Timbre sound absorption wall panel

Timbre Panel is an advanced interior finish that reproduces the texture and visual appearance of it's natural counterparts.

The panels come with perforated or slotted front faces to suit the room function acoustic requirement.

Advantages

- Available in sizes up to 3600 x 1200mm
- Available in any thickness from 2.5mm to 25mm
- Excellent acoustic and thermal insulation
- Flexible design characteristic
- Easy to handle, install and clean
- Cost effective sound control
- Available in curvable panels for radii as small as 50mm

Applications

The decorative surface is factory applied under controlled conditions to the visible face and profiled edges of the panel creating a prestigious, durable, pre-finished panel that is ideally suited to the following applications:

- Wall and ceiling linings
- Perforated and Slotted acoustic panels
- Curved panels
- Architraves
- Skirtings and mouldings

Jointing Options

- *Expressed Joint*
Expressed joints can be matched or contrasted to the panel finish, please refer the drawings on the next page
- *Cover mould*
- *Butt Joint*
Moulded edge profiles are recommended where butt jointing is selected to compensate for any minor variations in the structure or panel alignment. Consideration should also be given to expansion factors.

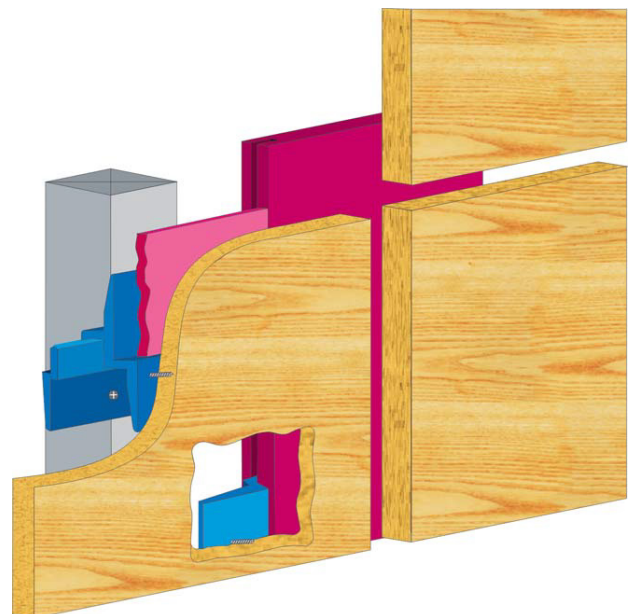

Edge Profile Options

The following standard edge profiles are available, with matching or contrasting decorative finishes. Custom profiles are available - consult Wilhams Technical Staff (minimum quantities may apply).



TP 01

TP 05



TP 02

TP 06



TP 03

TP 07



TP 04

TP 08

Installation

Timbre Panels are best mounted with a concealed fixing system.

Consideration should be given to reduced framing centres for higher impact areas such as corridors and crowded spaces, or where surfaces are to be curved. Timbre wall panels should be installed with a full perimeter support to minimise the risk of buckling. Allowance should be made between panels to accommodate swelling and building movement.

Jointing Details

Exposed Fixings

Exposed Joint

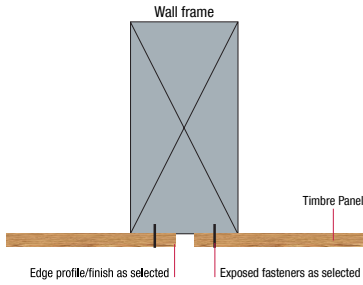

Exposed Joint-Shiplap

Also suitable for use with Timbre Panel Concealed Fixing System (Refer to Installation Systems)

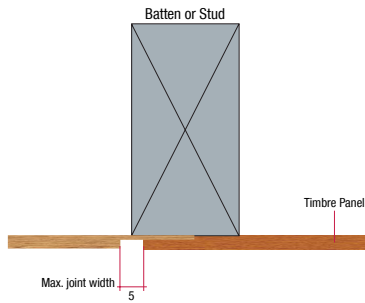

Cover Mould

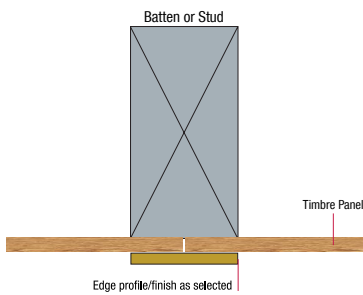

Butt Joint

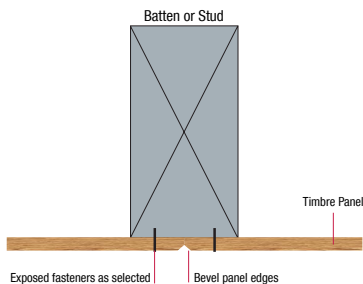

Concealed Fixings

Expressed Joint
Typical detail

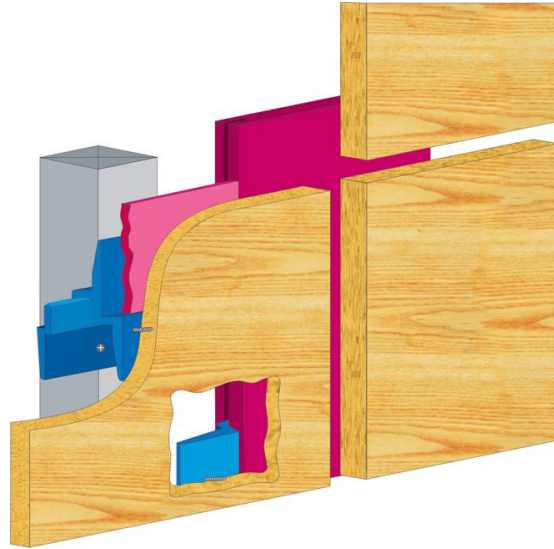

Expressed Joint - Plan View

Timbre Panel Concealed Fixing System

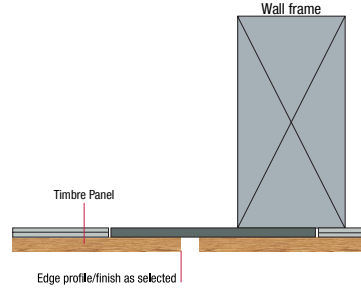

Butt Joint System

Typical detail

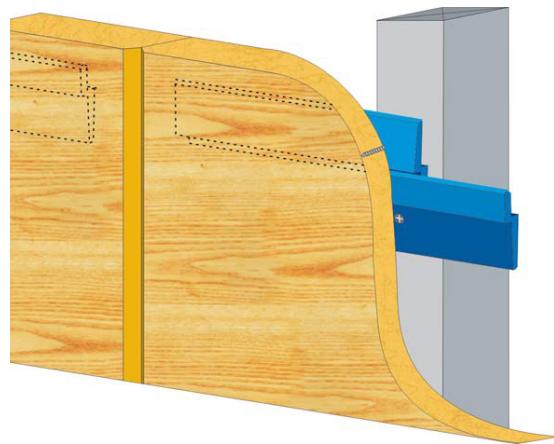

SoundPro® is the registered trademark of Wilhams Insulation Far East Sdn Bhd



Wilhams Insulation Far East Sdn Bhd

15 & 17 Jalan Utarid U5/23
Mah Sing Integrated Industrial Park
40150 Shah Alam, Selangor, Malaysia
Tel : 603-7846 6728 Fax : 603-7846 6540
E-mail : wilhams@wilhams.com.my
Website : www.wilhams.com.my

IMPORTANT NOTICE: Any directions for use are given for guidance only and are not intended to form part of any contract. They should be varied or adapted to suit your particular materials or conditions of use. Goods supplied by the company are made to approved standards from the highest quality raw materials but no warranty or guarantee is given as to their suitability for any particular purpose or application, and no liability is accepted for any loss or damage arising directly or indirectly from the use of the Company's products irrespective of any information given to us as to intended use of such products. It is therefore recommended that prospective users should test a sample of this product under their own conditions to satisfy themselves that the product to be used is suitable for that purpose intended.